

**REQUEST FOR PROPOSAL
WALKIE REACH TRUCK
RFP #2024-01-ARPS-HFB-GCFB-Walkie-truck**

DATE: April 24, 2024

The Galveston County Food Bank
624 4th Ave N
Texas City, TX 77590
Phone (409) 945-4232
Website <http://www.galvestoncountyfoodbank.org>

USDA Nondiscrimination Statement

In accordance with Federal civil rights law and U.S. Department of Agriculture (USDA) civil rights regulations and policies, the USDA, its Agencies, offices, and employees, and institutions participating in or administering USDA programs are prohibited from discriminating based on race, color, national origin, sex, disability, age, or reprisal or retaliation for prior civil rights activity in any program or activity conducted or funded by USDA.

Persons with disabilities who require alternative means of communication for program information (e.g. Braille, large print, audiotape, American Sign Language, etc.), should contact the Agency (State or local) where they applied for benefits. Individuals who are deaf, hard of hearing or have speech disabilities may contact USDA through the Federal Relay Service at (800) 877-8339. Additionally, program information may be made available in languages other than English.

To file a program complaint of discrimination, complete the [USDA Program Discrimination Complaint Form](http://www.ascr.usda.gov/complaint_filing_cust.html), (AD-3027) found online at: http://www.ascr.usda.gov/complaint_filing_cust.html, and at any USDA office, or write a letter addressed to USDA and provide in the letter all of the information requested in the form. To request a copy of the complaint form, call (866) 632-9992. Submit your completed form or letter to USDA by:

- (1) mail: U.S. Department of Agriculture
Office of the Assistant Secretary for Civil Rights
1400 Independence Avenue, SW
Washington, D.C. 20250-9410;
- (2) fax: (202) 690-7442; or
- (3) email: program.intake@usda.gov.

This institution is an equal opportunity provider.

April 24, 2024

The Galveston County Food Bank (GCFB) is securing bids for **one 3,000 pound capacity Walkie Reach Truck with a maintenance free battery and charger. Unit to be able to operate in freezer, refrigerated and warehouse spaces.** All materials are to be delivered and installed at Galveston County Food Bank located at: 624 4th Ave N, Texas City, TX 77590.

The Galveston County Food Bank (GCFB) is requesting bids for a new 3,000 capacity walkie reach truck. Truck is to be or similar to a Big Joe PDSR30 Walkie Reach with Power Steering.

See specification sheet at end of this RFP.

GENERAL CONDITIONS FOR BIDDERS:

Delivery

The Galveston County Food Bank is located at 624 4th Ave N, Texas City, TX 77590

Submission Guidelines

The Galveston County Food Bank is a tax exempt 501(c)(3) non-profit, our Tax Exemption Certificate shall be provided to the awarded bidder.

Bid period begins April 24, 2024 and ends at 5:00 PM on May 23, 2024 at the Galveston County Food Bank.

1. Bids shall be executed and submitted via e-mail. Please submit to Donnie Van Ackeren donnie@galvestoncountyfoodbank.org
 - a. Please include in the Email Subject Line: 2024-01-ARPA-HFB-GCFB-Walkie Truck. Should you have any questions concerning this request for proposals, please let us know via email donnie@galvestoncountyfoodbank.org.

Sincerely,

Donnie Van Ackeren
President
Galveston County Food Bank

Section 1

REQUEST FOR PROPOSALS

This document contains a Request for Proposals for one Walkie Reach Truck. The Galveston County Food Bank operates TEFAP, CSFP, SFSP, and CACFP established by the United States Department of Agriculture and sets forth the terms and conditions applicable to the proposed procurement. Upon acceptance, this document shall constitute the award between the successful bidder and the Institution. (Accepting a bid does not constitute acceptance of the contract.)

Soliciting Institution:

Galveston County Food Bank
624 4th Ave N
Texas City, TX 77590
(409) 945-4232

Bid number: 2024-01-ARPA-HFB-GCFB-Walkie Truck

Bid Issue Date: April 24, 2024

Bid Due Date: May 23, 2024

Bid Review Date: May 24, 2024

Prompt Payment Discount: _____ % for payment within ____ days *(completed by bidder)*

Total Estimated Amount of Bid: _____ *(completed by bidder - in lieu of completing, bidders may supply additional bid amount detail on attachment)*

By submission of this bid, the bidder certifies that, in the event he receives an award under this solicitation, he shall operate in accordance with all applicable, current program regulations.

Name of Bidder: _____	Name of Authorized Representative: _____
_____ <i>Print or Type Name of Company</i>	_____ <i>Print or Type Name of Representative</i>
Street Address: _____	By: _____
_____	_____ <i>Signature of Representative</i>
City, State, and Zip Code: _____	Title: _____
_____	Date: _____
Telephone Number: _____	_____
_____	_____

ACCEPTANCE

Bid Name & Number:
2024-01-ARPA-HFB-GCFB-Walkie Truck

Institution Name:

Galveston County Food Bank

Institution's Authorized Representative:

Donnie Van Ackeren
Title: President and CEO

_____ *Institution Signature*

Date: _____

Section 2

**Certificate of Independent
Price Determination**

- (a) By submission of this bid, the bidder certifies, and in the case of a joint bid, each party thereto certifies, as to its own organizations, that in connection with this procurement:
1. The prices in this bid have been arrived at independently, without consultation, communication or agreement, for the purpose of restricting competition, as to any matter relating to such prices with any other bidder or with any competitor;
 2. Unless otherwise required by law, the prices which have been quoted in this bid have not been knowingly disclosed by the bidder and will not knowingly be disclosed by the bidder prior to bid opening, directly or indirectly to any other bidder or to any competitor; and
 3. No attempt has been made or will be made by the bidder to induce any person or firm to submit or not to submit, a bid for the purpose of restricting competition.
- (b) Each person signing this bid certifies that:
- The person in the bidder's organization is responsible within that organization for the decision as to the prices being offered herein and that he has not participated, will not participate, in any action contrary to (a)(1) through (a)(3) above; or
 - The person in the bidder's organization is not responsible within that organization for the decision as to the prices being offered herein but that he has been authorized in writing to act as agent for the persons responsible for such decision in certifying that such persons have not participated and will not participate, in any action contrary to (a)(1) through (a)(3) above, and as their agent does hereby so certify; and he has not participated, and will not participate, in any action contrary to (a)(1) through (a)(3) above.

Signature of bidder's authorized representative

Title _____ Date _____

In accepting this bid, the Institution certifies that the Institution's officers, employees or agents have not taken any action which may have jeopardized the independence of the bid referred to above. (Accepting a bid does not constitute acceptance of the contract.)

Signature of Authorized Institution Representative

Note: Institution and Bidder shall execute this Certificate of Independent Price Determination.

Section 3

Instructions to Bidders

1. Definitions

As used herein:

- a) The term “bid” means an offer to perform the work described in this Request for proposals at the fixed unit price specified in accordance with the terms and conditions of the solicitation.
- b) The term “bidder” refers to a company submitting a bid in response to this Request for proposals.
- c) The term “contractor” means a successful bidder who is awarded a contract by an Institution under The Emergency Food Assistance Program (TEFAP), Commodity Supplemental Food Program (CSFP), Child and Adult Care Food Program (CACFP), and Summer Food Service Program (SFSP) under the U. S. Department of Agriculture.
- d) The term “Request for proposals”, hereafter referred to as RFP, means the document soliciting bids through the formal advertising method of competitive sealed bid procurement.
- e) The term “Institution” means the Galveston County Food Bank that operates TEFAP, CSFP, CACFP, and SFSP Program which is issuing this RFP.
- f) The Institution’s contact is Donnie Van Ackeren, President or Jeff Gordon, Special Projects – Donnie@galvestoncountyfoodbank.org or jeff@galvestoncountyfoodbank.org.
- g) The term “responsive” means the bidder conforms to all material terms and conditions of the RFP.
- h) The term “responsible” means the bidder is capable of successfully performing under the terms and conditions of the contract.

Other terms shall have the meanings ascribed to them in TEFAP, CSFP, CACFP, and SFSP regulations.

2. Submission of Bids

- a) Bidders are expected to examine carefully the specifications, schedules, attachments, terms and conditions of this RFP. Failure to do so shall be at the bidder’s risk.
- b) Bids shall be executed and submitted by email.
- c) The copy marked “original” shall be governing should there be a variance between that copy of the bid and other copies submitted by the bidder. No

changes in the specifications or general conditions are allowed. Erasures on this bid shall be initialed by the bidder prior to submission.

- i) If accepted, this RFP will be signed by an authorized representative of the Institution and a fully executed copy will be forwarded to the successful bidder as the notice of award.
- d) The successful bidder shall provide a contract, using the specifications outlined in this RFP to the Galveston County Food Bank by **5:00 PM May 23, 2024** to the attention of Donnie Van Ackeren, donnie@galvestoncountyfoodbank.org.
- e) An interested party may protest the solicitation, the cancellation of the solicitation, or the award or proposed award of a contract in writing by contacting The GCFB President via email at donnie@galvestoncountyfoodbank.org.

Failure to comply with any of the above shall be reason for rejection of the bid.

3. Explanation to Bidders

Any explanation/questions desired by a bidder regarding the meaning or interpretation of the RFP specifications, etc., must be requested by email to donnie@galvestoncountyfoodbank.org by **5:00 PM on May 1, 2024** to allow sufficient time allowed for a reply to reach all bidders before bid opening.

Oral explanations or instructions given before the award of the contract shall not be binding. Any information given to a prospective bidder concerning an RFP shall be furnished to all prospective bidders as an amendment to the RFP if such information is necessary to bidders in submitting bids on the RFP or if the lack of such information would be prejudicial to uninformed bidders.

4. Acknowledgment of Amendments to Submitted Bids

Receipt of an amendment to a bid by a bidder must be acknowledged by signing and returning the amendment. Such acknowledgment must be received prior to the hour and date specified for bid opening.

5. Discounts

Although a blank is provided for a time discount, prompt payment discounts offered for payment in less than twenty calendar days will not be considered in evaluating bids for award. However, offered discounts of less than twenty days will be taken if payment is made within the discount period even though not considered in the evaluation of bids. (NOTE: Payment discounts may only be used to determine the low bid when prior experience of the Institution indicates that such discounts are generally taken).

6. Bidders Having Interest in More than One Bid

If more than one bid is submitted by any one person, by or in the name of a clerk, partner, or other person, all such bids shall be rejected.

7. Time for Receiving Bids

Sealed bids shall be deposited at the address specified on the RFP of the Institution no later than the exact time and date indicated on the face of this RFP. Bids received prior to the time of opening will be securely kept, unopened.

8. Error in Bids

Bidders or their authorized representatives are expected to fully inform themselves as to the conditions, requirements and specifications before submitting bids; failure to do so shall be at the bidder's own risk and he cannot secure relief on the plea of error.

9. Award of Contract

- a) The contract will be awarded to the best responsive and responsible bidder meeting the specific requirements.
- b) The Institution reserves the right to reject any or all bids when there are sound documented business reasons in the best interest of the Program and to waive informalities and minor irregularities in bids received.
- c) The Institution reserves the right to reject the bid of a bidder who has previously failed to perform properly or complete on time contracts of a similar nature, or the bid of a bidder who investigation shows is not in a position to perform the contract. Other factors that may be considered include, but are not limited to the bidder's integrity, compliance with public policy, and financial and technical resources.

10. Late Bids, Modifications of Bids or Withdrawals of Bids

- a) Any bid received after the exact time specified for receipt will not be considered.
- b) A bid may also be withdrawn in person by a bidder or his authorized representative, provided his identity is made known and he signs a receipt for the bid, but only if the withdrawal is made prior to the exact time set for receipt of bids.
- c) The only acceptable evidence to establish the date of emailing of a late bid, modifications or withdrawal is providing evidence of the sent time of the email in the form of a screenshot displaying the time and date with the subject line listed above.

11. Confidentiality

- a) Bidder covenants that all data, documents, discussion, or other information developed or received by bidder or provided for performance of this Agreement are deemed confidential and shall not be disclosed by Bidder without written authorization by GCFB.
- b) GCFB shall grant such authorization if disclosure is required by law. Bidder's covenant under this Section shall survive the termination of this Agreement.

12. Addition and Removal of Locations

- a) GCFB is required periodically to increase or decrease its fleet size and locations due to changes in demand.
- b) GCFB needs the flexibility to communicate these changes to the contractor and easily update the contract under the existing contract terms and without incurring excessive additional cost for the changes.

13. Bidder Selection

GCFB intends to select the bid with the best value based on the scoring matrix, but it reserves the right to choose multiple bidders in order to meet the needs of GCFB.

Section 4 Scope

The Galveston County Food Bank (GCFB) is securing bids for **one 3,000 pound capacity Walkie Reach Truck with a maintenance free battery and charger. Unit to be able to operate in freezer, refrigerated and warehouse spaces.** All materials are to be delivered and installed at Galveston County Food Bank located at: 624 4th Ave N, Texas City, TX 77590.

The Galveston County Food Bank (GCFB) is requesting bids for a new 3,000 capacity walkie reach truck. Truck is to be or similar to a Big Joe PDSR30 Walkie Reach with Power Steering.

See specification sheet at end of this RFP.

Walkie Reach Truck Specifications

1. Please see attached specification sheet for a 3,000 pound walkie reach truck.
2. Measurements: Refrigerated space door height 96 inches, second level storage rack height 72 inches.
3. Include maintenance free battery and charger.
4. Provide instructions and assistance for operating and product warranties.
5. Provide estimated delivery date.
6. Any catalog, brand name or manufacturer's references used in this RFB is descriptive only (not restrictive) and is to indicate type and quality desired. Bids of like nature and quality will be considered unless advertised under a proprietary justification.
If bidding on other than referenced brand(s) specified, Bidder **must** submit as part of their bid the following:
An exception list to indicate where the alternate product(s) quoted differs from that specified in this RFP.
Descriptive literature, illustrations, and/or specifications of quoted product(s).
NOTE: If no exception is taken to reference data or specifications, Bidder will be required to furnish the exact brand name(s)/product(s) as specified.
7. Price to include delivery to GCFB, 624 4th Ave N., Texas City TX
8. Please provide 3 references

Section 5 Submission Criteria

Provide the following information in the response lines below or attached to the submitted RFP.

A. Costs – The purchase price plus the total long-term cost to the Galveston County Food Bank to acquire the Contractor’s goods or services. Please provide details about the type of pricing used (i.e. Bill Rate, Mark-up, etc) by Contractor and break down the different elements of the pricing including fees, taxes, etc. Provide any additional cost details in the lines below:

B. Description of Bidder – include locations of offices and persons responsible for services and point of contact for Galveston County Food Bank.

C. Statement of understanding of the services requested – include a narrative and work plan outlining an approach for addressing the requirements of the RFP

D. Quality of previous work – Examples of supplies and equipment requested as well as client testimonials and references

*E. Statement of the bidder's qualifications and financial capability as they relate to the scope of services – copies of recent audit, a current financial statement or a copy of the contractor's federal income tax return with all amendments preferred. **References from a minimum of 3 sources preferred.***

F. Technical Expertise and Experience: Provide descriptions and documentation of staff technical expertise and experience

G. Additional services: Additional services outside the listed scope of services supplier will provide i.e. green initiative and social responsibility, inventory management, etc.

H. Additional information the bidder deems appropriate to assist in evaluating the proposal. Additional points will be awarded to Minority (MBE), HUB, Women-owned (WBE), Disadvantaged (DBE), Persons with Disabilities (PDBE), Veteran (VBE), Service Disabled Veteran (SDVBE) or Small (SBE) Business Enterprises with proof of these classifications.

Evaluation of Bidders

Each bidder will be evaluated on the following factors:	Total Possible Points
1 copy of the bid submitted by email with signatures	Required
Bidder representative signatures: <ul style="list-style-type: none"> • RFP Solicitation – pg. 4 • Certificate of Independent Price Determination – pg. 5 • Clean Air and Water Certification – pg. 23 • Form AD-1048 – pg. 24 • Certification Regarding Lobbying – pg. 27 	Required
A. Cost of Goods and Services	55
B. Description of Bidder	5
C. Statement of Understanding	8
D. Quality of previous work	7
E. Statement of the bidders' qualifications and financial capability - higher points given to complete financial, tax or audit records and references from 3 sources.	5
F. Technical Expertise and Experience	5
G. Additional Services	5
H. Additional relevant information - higher points given to those with proof of certification.	10
Max Possible Points	100

Section 6

General Conditions

1. Length of Contract

This contract will be in effect for 12 months beginning May 24, 2024 or date of agreement approval by the Galveston County Food Bank and shall end April 30, 2023, with the option to renew for one (1) additional year.

2. Payment

Invoices should be e-mailed to: PAYABLES@galvestoncountyfoodbank.org

It is the Galveston County Food Bank's policy to pay in full in net 30 days.

3. Termination Clause

The successful bidder's contract must include the following termination provisions:

- a) **For cause** - by Institution or contractor with thirty (30) days written notification.
- b) **The Institution's right to terminate** - If the contractor fails to comply with any of the requirements of the contract. The Institution shall notify the contractor of specific instances of noncompliance, in writing. In instances where the contractor has been notified of noncompliance with the terms of the contract and has not taken immediate corrective action, the Institution shall have the right, upon written notice, of immediate termination of the contract and the contractor shall be liable for any damages incurred by the Institution. The Institution shall negotiate a repurchase contract on a competitive basis to arrive at a fair and reasonable price.
- c) The Institution shall, by written notice to the contractor, terminate the right of the contractor to proceed under this contract if it is found by the Institution that gratuities in the form of entertainment, gifts, favors, anything of monetary value or otherwise were offered or given by the contractor or contractor's employees or subcontractors to any officer, employee or agent of the Institution.
- d) In the event this contract is terminated as provided in paragraph (b) hereof, the Institution shall be entitled: (i) to pursue the same remedies against the contractor as it could pursue in the event of a breach of the contract by the contractor;
- e) and (ii) as a penalty, in addition to any other damages in any amount which shall not be less than three, nor more than ten times the costs incurred by the contractor in providing any such gratuities to any such officer or employee.
- f) The rights and remedies of the Institutions provided in this clause, shall not be exclusive, and are in addition to any other rights and remedies provided by law or under this contract.

Section 7

General Provisions

Equal Opportunity

(The following clause is applicable unless this contract is exempt under the rules, regulations, and relevant orders of the Secretary of Labor [41 CFR ch. 60].)

During the performance of the contract, the contractor agrees as follows:

- a) The contractor will not discriminate against any employee or applicant for employment because of race, color, religion, sex, age, disability, or national origin. The contractor will take affirmative action to ensure that applicants are employed, and that employees are treated during employment without regard to their race, color, religion, sex, age or national origin. Such action shall include, but not be limited to, the following: employment, upgrading, demotion, or transfer; recruitment or recruitment advertising; layoff or termination; rates of pay or other forms of compensation; and selection for training, including apprenticeship. The contractor agrees to post in conspicuous places, available to employees and applicants for employment, notices to be provided by the Contracting Officer setting forth the provisions of this Equal Opportunity clause.
- b) The contractor will, in all solicitation or advertisements for employees placed by or on behalf of the contractor, state that all qualified applicants will receive consideration for employment without regard to race, color, religion, sex, age, disability or national origin.
- c) The contractor will send to each labor union or representative of workers with which he has a collective bargaining agreement or other contract or understanding, a notice, to be provided by the agency Contracting Officer, advising the labor union or workers' representative of the contractor's commitments under this Equal Opportunity clause, and shall post copies of the notice in conspicuous places available to employees and applicants for employment.
- d) The contractor will comply with all provisions of Executive Order No. 11246 of September 24, 1965, as amended by Executive Order No. 11375 of October 13, 1967, and of the rules, regulations, and relevant orders of the Secretary of Labor.
- e) The contractor will furnish all information and reports required by Executive Order No. 11246 of September 24, 1965, as amended by Executive Order No. 11375 of October 13, 1967, and by the rules, regulations, and orders of the Secretary of Labor, or pursuant thereto, and will permit access to his books, records, and accounts by the contracting agency and the Secretary of Labor for purposes of investigation to ascertain compliance with such rules, regulations, and orders.
- f) In the event of the contractor's noncompliance with the Equal Opportunity clause of this contract or with any of the said rules, regulations, or orders, this contract may be canceled, terminated, or suspended, in whole or in part, and the contractor may be declared ineligible for further Government contracts in accordance with Procedures

authorized in Executive Order 11246 of September 24, 1965, as amended by Executive Order No. 11375 of October 13, 1967, and such other sanctions as may be imposed and remedies invoked as provided in Executive Order No. 11246 of September 24, 1965, as amended by Executive Order 11375 of October 13, 1967, or by rule, regulations, or order of the Secretary of Labor, or as otherwise provided by law.

- g) The contractor will include the provisions of paragraphs a) through g) in every subcontract or purchase order unless exempted by rules, regulations, or orders of the Secretary of Labor issued pursuant to Section 204 of Executive Order No. 11246 of September 24, 1965, as amended by Executive Order No. 11375 of October 13, 1967, so that such provisions will be binding upon each subcontractor or Institution. The contractor will take such action with respect to any subcontract or purchase order as the contracting agency may direct as a means of enforcing such provisions, including sanctions for noncompliance: Provided, however, that in the event the contractor becomes involved in, or is threatened with, litigation with a subcontractor or Institution as a result of such direction by the contracting agency, the contractor may request the United States to enter into such litigation to protect the interests of the United States.

Clean Air and Water

(Applicable only if the contract exceeds \$100,000 or the Contracting Officer has determined that the orders under an indefinite quantity contract in any one year will exceed \$100,000, or a facility to be used has been the subject of a conviction under the Clean Air Act [42 USC 7413(c)(1) or the Federal Water Pollution Control Act [33 USC 1319(c)] and is listed by EPA, or the contract is not otherwise exempt.)

- a) The contractor agrees as follows:
- i) To comply with all the requirements of Section 114 of the Clean Air Act, as amended [42 USC 7414] and Section 308 of the Federal Water Pollution Control Act [33 USC 1251, et seq.], respectively, relating to inspection, monitoring, entry, reports and information as well as other requirements specified in Section 114 and Section 308 of the Air Act and the Water Act, respectively, and all regulations and guidelines issued hereunder before the award of this contract.
 - ii) That no portion of the work required by this contract will be performed in a facility listed on the Environmental Protection Agency List of Violating Facilities on the date when this contract was awarded unless and until the EPA eliminates the name of such facility or facilities from such listing.
 - iii) To use his best efforts to comply with clean air standards and clean water standards at the facilities in which the contract is being performed.
 - iv) To insert the substance of the provisions of this clause in any nonexempt subcontract, including this paragraph (a)(4).
- b) The terms used in this clause have the following meanings:

- i) The term "Air Act" means the Clean Air Act, as amended [42 USC 7401, et seq.].
- ii) The term "Water Act" means Federal Water Pollution Control Act, as amended [33 USC 1251 et seq.].
- iii) The term "Clean Air Standards" means any enforceable rules, regulations, guidelines, standards, limitations, orders, controls, prohibitions, or other requirements which are contained in, issued under, or otherwise adopted pursuant to the Air Act or Executive Order 11738, an applicable implementation plan as described in Section 110(d) of the Clean Air Act [42 USC 7410], an approved implementation procedure or plan under Section 111(c) or Section 111(d), respectively, of the Air Act [42 USC 7411] or Section 111(d), respectively, of the Air Act [42 USC 7411], or an approved implementation procedure under Section 112(d) of the Air Act [42 USC 7412].
- iv) The term "Clean Water Standards" means any enforceable limitation, control, condition, prohibition, standard, or other requirement which is promulgated pursuant to the Water Act or contained in a permit issued to a discharger by the Environmental Protection Agency or by a State under an approved program, as authorized by Section 402 of the Water Act [33 USC 1342] or by local government to ensure compliance with pretreatment regulations, as required by Section 307 of the Water Act [33 USC 1317].
- v) The term "compliance" means compliance with clean air or water standards. Compliance shall also mean compliance with a schedule or plan ordered or approved by a court of competent jurisdiction, the Environmental Protection Agency or an Air or Water Pollution Control Agency in accordance with the requirements of the Air Act or Water Act and regulations issued pursuant thereto.
- vi) The term "facility" means any building, plant, installation, structure, mine, vessel, or other floating craft, location or sites of operations, owned, leased or supervised by a contractor or subcontractor to be utilized in the performance of a contract or subcontracts. Where a location or site of operations contains or includes more than one building, plant, installation, or structure, the entire location or site shall be deemed to be a facility except where the Director, Office of Federal Activities, Environmental Protection Agency, determines that independent facilities are co-located in one geographical area.

Clean Air and Water Certification

The bidder certifies as follows:

- a) Any facility to be utilized in the performance of this proposed contract has , has not been listed on the Environmental Protection Agency List of Violating Facilities.
- b) He will promptly notify the Contracting Officer, prior to award, of the receipt of any communication from the Director, Office of Federal Activities, U. S. Environmental Protection Agency, indicating that any facility which he proposes to use for the performance of the contract is under consideration to be listed on the EPA List of Violating Facilities.
- c) He will include substantially this certification, including this paragraph c) in every nonexempt subcontract.

Signature of Authorized Representative, Bidder

Date

Energy Policy and Conservation Act (42 USC 6201, et seq.)

The contractor shall comply with all mandatory standards and policies relating to energy efficiency which are contained in the State energy conservation plan issued in compliance with the Energy Policy and Conservation Act (42 USC 6201, et seq.)

Contract Work Hours and Safety Standards Act-Overtime Compensation

The contractor shall comply with Sections 103 and 107 of the Contract Work Hours and Safety Standards Act (the "Act"), 40 USC 3702, 3704, as supplemented by Department of Labor regulations, 29 CFR, Part 5. Under Section 103 of the Act, contractor shall be required to compute the wages of every laborer on the basis of a standard workweek of 40 hours. Work in excess of the standard workweek is permissible provided that the worker is compensated at a rate of not less than 1 ½ times the basic rate of pay for all hours worked in excess of 40 hours in any workweek. Section 107 of the Act provides that no laborer or mechanic shall be required to work in surroundings or under working conditions, which are unsanitary, hazardous or dangerous to his health and safety as determined under construction, safety and health standards promulgated by the Secretary of Labor.

Section 8

U. S. DEPARTMENT OF AGRICULTURE

**Certification Regarding Debarment, Suspension, Ineligibility
And Voluntary Exclusion - Lower Tier Covered Transactions**

This certification is required by the regulations implementing Executive Order 12549, Debarment and Suspension, 7 CFR Part 417, Section 417.332, Participants' responsibilities.

(BEFORE COMPLETING CERTIFICATION, READ INSTRUCTIONS ON REVERSE)

- 1) The prospective lower tier participant certifies, by submission of this proposal, that neither it nor its principals is presently debarred, suspended, proposed for debarment, declared ineligible or voluntarily excluded from participation in this transaction by any Federal department or agency.
- 2) Where the prospective lower tier participant is unable to certify to any of the statements in this certification, such prospective participant shall attach an explanation to this proposal.

Organization Name
Name

PR/Award Number or Project

Name(s) and Title(s) of Authorized Representative(s)

Signature(s)

Date

Form AD-1048 (1/92)

Instructions for Certification

1. By signing and submitting this form, the prospective lower tier participant is providing the certification set out on the reverse side in accordance with these instructions.
2. The certification in this clause is a material representation of fact upon which reliance was placed when this transaction was entered into. If it is later determined that the prospective lower tier participant knowingly rendered an erroneous certification, in addition to other remedies available to the Federal Government, the department or agency with which this transaction originated may pursue available remedies, including suspension and/or debarment.
3. The prospective lower tier participant shall provide immediate written notice to the person to which this proposal is submitted if at any time the prospective lower tier participant learns that its certification was erroneous when submitted or has become erroneous by reason of changed circumstances.
4. The terms “covered transaction”, “debarred”, “suspended”, “ineligible”, lower tier covered transaction”, “participant”, “person”, “primary covered transaction”, “principal”, “proposal”, and “voluntarily excluded”, as used in this clause, have the meanings set out in the Definitions and Coverage sections of rules implementing Executive Order 12549. You may contact the person to which this proposal is submitted for assistance in obtaining a copy of those regulations.
5. The prospective lower tier participant agrees by submitting this form that, should the proposed covered transaction be entered into, it shall not knowingly enter into any lower tier covered transaction with a person who is debarred, suspended, declared ineligible, or voluntarily excluded from participation in this covered transaction, unless authorized by the department or agency with which this transaction originated.
6. The prospective lower tier participant further agrees by submitting this form that it will include this clause titled “Certification Regarding Debarment, Suspension, Ineligibility and Voluntary Exclusion - Lower Tier Covered Transactions”, without modification, in all lower tier covered transactions and in all solicitations for lower tier covered transactions.
7. A participant in a covered transaction may rely upon a certification of a prospective participant in a lower tier covered transaction that it is not debarred, suspended, ineligible, or voluntarily excluded from the covered transaction, unless it knows that the certification is erroneous. A participant may decide the method and frequency by which it determines the eligibility of its principals. Each participant may, but is not required to, check the Non-Procurement List.
8. Nothing contained in the foregoing shall be construed to require establishment of a system of records in order to render in good faith the certification required by this clause. The knowledge and information of a participant is not required to exceed that which is normally possessed by a prudent person in the ordinary course of business dealings.

9. Except for transactions authorized under paragraph 5 of these instructions, if a participant in a covered transaction knowingly enters into a lower tier covered transaction with a person who is suspended, debarred, ineligible, or voluntarily excluded from participation in this transaction, in addition to other remedies available to the Federal Government, the department or agency with which this transaction originated may pursue available remedies, including suspension and/or debarment.

Form AD-1048 (1/92)

Section 9

**PROCUREMENT
Certification Regarding Lobbying**

Applicable to Grants, Sub-grants, Cooperative Agreements, and Contracts exceeding
\$100,000 in Federal funds.

Submission of this certification is a prerequisite for making or entering into this transaction and is imposed by section 1352, Title 31, U.S. Code. This certification is a material representation of fact upon which reliance was placed when this transaction was made or entered into. Any person who fails to file the required certification shall be subject to a civil penalty of not less than \$10,000 and not more than \$100,000 for each such failure.

The undersigned certifies, to the best of his or her knowledge and belief, that:

- (1) No Federal appropriated funds have been paid or will be paid by or on behalf of the undersigned, to any person for influencing or attempting to influence an officer or employee of any agency, a Member of Congress, an officer or employee of Congress, an employee of a Member of Congress, or any Board Member, officer, or employee of **GCFB** in connection with the awarding of a Federal contract, the making of a Federal grant, the making of a Federal loan, the entering into a cooperative agreement, and the extension, continuation, renewal, amendment, or modification of a Federal contract, grant, loan, or cooperative agreement.
- (2) If any funds other than Federal appropriated funds have been paid or will be paid to any person for influencing or attempting to influence an officer or employee of any agency, a Member of Congress, an officer or employee of Congress, an employee of a Member of Congress, or any Board Member, officer, or employee of **GCFB** in connection with this Federal grant or cooperative agreement, the undersigned shall complete and submit Standard Form-LLL, "Disclosure Form to Report Lobbying", in accordance with its instructions.
- (3) The undersigned shall require that the language of this certification be included in the award documents for all covered sub-awards exceeding \$100,000 in Federal funds at all appropriate tiers and that all sub-recipients shall certify and disclose accordingly.

Name/Address of Organization

Name/Title of Submitting Official

Signature

Date

Section 9 (cont.)

Disclosure of Lobbying Activities

Complete this form to disclose lobbying activities pursuant to 31 U.S.C. 1352

disclosure.)

(See next page for public burden

Approved by OMB

0348-0046

<p>1. Type of Federal Action:</p> <p><input type="checkbox"/> a. contract</p> <p><input type="checkbox"/> b. grant</p> <p><input type="checkbox"/> c. cooperative agreement</p> <p><input type="checkbox"/> d. loan</p> <p><input type="checkbox"/> e. loan guarantee</p> <p><input type="checkbox"/> f. loan insurance</p>	<p>2. Status of Federal Action:</p> <p><input type="checkbox"/> a. bid/offer/application</p> <p><input type="checkbox"/> b. initial award</p> <p><input type="checkbox"/> c. post-award</p>	<p>3. Report Type:</p> <p><input type="checkbox"/> a. initial offering</p> <p><input type="checkbox"/> b. material change</p> <p>For Material Change Only:</p> <p>Year _____</p> <p>Quarter _____</p> <p>Date of last report _____</p>
<p>4. Name and Address of Reporting Entity:</p> <p><input type="checkbox"/> Prime</p> <p><input type="checkbox"/> Sub-awardee, Tier _____, <i>if known</i></p> <p>_____</p> <p>Congressional District, <i>if known</i>:</p>	<p>5. If Reporting Entity in No. 4 is Sub-awardee, Enter Name & Address Of Prime:</p> <p>_____</p> <p>Congressional District, <i>if known</i>:</p>	
<p>6. Federal Department/Agency:</p>	<p>7. Federal Program Name/Description:</p> <p>CFDA Number, <i>if applicable</i>: _____</p>	
<p>8. Federal Action Number, <i>if known</i>:</p>	<p>9. Award Amount, <i>if known</i>:</p> <p>\$ _____</p>	

<p>10. a. Name and Address of Lobbying Entity (If individual, last name, first name, MI):</p> <p>(Attach continuation sheet(s) if necessary)</p>	<p>b. Individuals Performing Services (Incl. Address if different from No. 10a) (last name, first name, MI):</p>
<p>11. Amount of Payment (check all that apply):</p> <p>\$ _____</p> <p><input type="checkbox"/> Actual <input type="checkbox"/> Planned</p>	<p>13. Type of Payment (check all that apply):</p> <p><input type="checkbox"/> a. retainer</p> <p><input type="checkbox"/> b. one-time fee</p> <p><input type="checkbox"/> c. commission</p> <p><input type="checkbox"/> d. contingent fee</p> <p><input type="checkbox"/> e. deferred</p> <p><input type="checkbox"/> f. other; specify: _____</p>
<p>12. Form of Payment (check all that apply):</p> <p><input type="checkbox"/> a. cash</p> <p><input type="checkbox"/> b. in-kind; specify:</p> <p> nature _____</p> <p> value _____</p>	
<p>14. Brief Description of Services Performed or to be Performed and Date(s) of Service, including officer(s), employee(s), or member(s) contacted for Payment Indicated in Item 11:</p> <p>(Attach continuation sheet(s) if necessary)</p>	
<p>15. Continuation Sheet(s) attached: <input type="checkbox"/> Yes <input type="checkbox"/> No</p>	
<p>16. Information requested through this form is authorized by article 31 U.S.C. section 1352. This disclosure of lobbying activities is a material representation of fact upon which reliance was placed by the tier above when this transaction was made or entered into. This disclosure is required pursuant to 31 U.S.C. 1352. This information</p>	<p>Signature: _____</p> <p>Print Name: _____</p> <p>Title: _____</p> <p>Telephone No: _____ Date: _____</p>

will be reported to the Congress semi-annually and will be available for public inspection. Any person who fails to file the required disclosure shall be subject to civil penalty of not less than \$10,000 and not more than \$100,000 for each such failure.

Federal Use Only:

Authorized for Local Reproduction of: Standard Form - LLL

Big Joe – PDSR30 – 3,000# Walkie Reach Truck – Sourcewell
ETA: 2 -3 Weeks Delivery

HIGHLIGHTS

PDSR
Walkie Reach
w/ Power Steering

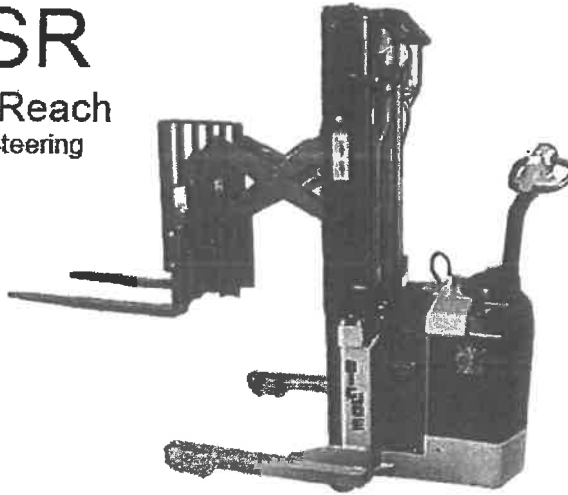

CONFIGURATION

CHASSIS	1	3,000# Walkie Reach Truck
RATINGS & STANDARDS	1	UL Rated Type E
MAST	1	189" MFH /88.3" OAL / 41.0" FFH Triplex
FORKS	1	42" Pallet Forks
BASELEG	1	42" Inside-to-Inside
BATTERY	1	Maintenance Free Battery and Charger



PDSR30

Power Steering Walkie Reach Truck

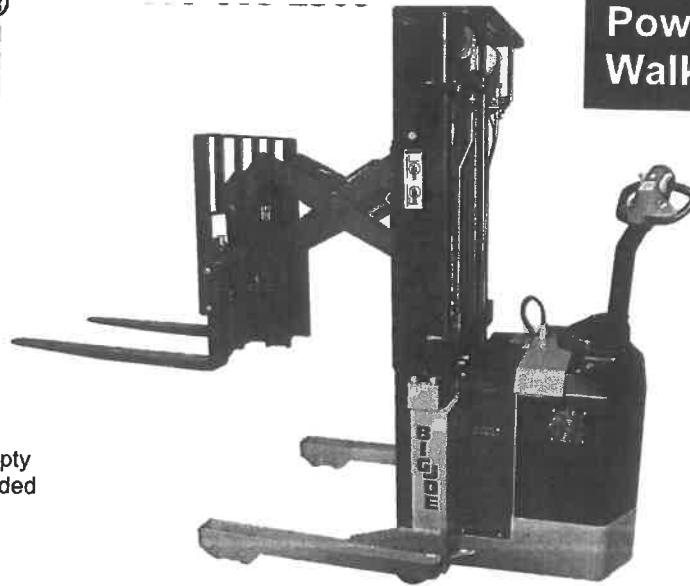

CAPACITY

3000 lbs. at 24" load center

BATTERY COMPARTMENTS

31.6" x 9.06" x open

31.6" x 13.1" x open (PDSR30-189)

SPEED

ZAPI travel controller

TRAVEL

Variable from 0 mph to 3.4 mph empty

Variable from 0 mph to 3.1 mph loaded

LIFT

Up to 40 fpm empty.

Up to 35 fpm loaded—3000lbs

LOWERING

Up to 29 fpm empty.

Up to 57 fpm loaded—3000lbs

WEIGHT

3,690-4,200lbs Chassis Only

TIRES / WHEELS

DRIVE

10" x 4" polyurethane

DUAL LOAD

(2) 4" x 2.75" polyurethane

HYDRAULICS

Lift cylinder has hard chrome plated rods. Pump unit including motor, solenoid, gear pump, and pressure compensated lowering valve are mounted high in the power compartment for ease of service.

ELECTRICAL

24-Volt ZAPI AC O inverter, travel control with matching drive motor provide high performance throughout the entire speed range. Travel speed remains constant relative to throttle position regardless of load. Separately fused power control circuits, quick disconnect EPD power cut off, and hour meter / battery discharge indicator combination gauge complete the system. Power configurations and diagnostic features are displayed with a ZAPI handheld console.

BRAKES

Regenerative electromagnetic brake is mounted on the motor armature shaft multiplying the braking power through the transmission.

Brake is applied when the control arm is in the vertical or horizontal handle position. Travel speed is reduced when forks are above 12" fork height. Neutral braking resists roll back on ramps.

CONTROLS

Travel, lift, and lower functions are located in the ergonomic operator handle. All operator controls are accessible without having to lift the hand from the handle.

Angle grips are designed to allow easy operation with either hand. Wrap around guard, reversing switch, thumb control, and horn are standard.

Top mounted tiller arm offers excellent operator comfort and minimum steering effort. Gas assisted spring gently returns handle to vertical position.

TRANSMISSION

Vertically mounted drive motor is direct mounted to gear housing. Oil bathed ZF GK10 hypoid bevel gear drive train with tapered roller bearings transfers power to axle. State of the art optimized gear technology supplies advantages such as minimal envelope circle, zero maintenance, low noise level, high efficiency and high performance.

MAST & PANTOGRAPH

I-beam mast with dual lifting chains. Pantograph stroke extends the fork carriage beyond the units straddle legs, with integral tilt and sideshift.

STRADDLE LEGS & FORKS

Fixed straddle leg inside dimensions (ID) available at 34" or 42" resulting in a 42" or 50" outside dimension (OD)

Class two ITA fork carriage with 36" tall load back rest. 42" Forks are adjustable.

BEARINGS

Drive Wheels: Tapered roller bearings sealed in oil bath

Load Wheels: Sealed ball bearings

ACCESSIBILITY

Removal of two piece power head cover exposes major components for inspection and maintenance

STANDARD EQUIPMENT

- Power Steering
- Pantograph with Sideshift and Tilt
- Proportional Lift, Lower & Extend
- Regenerative Neutral Braking
- Low Battery – Interrupt
- Hour Meter BDI Combo Gauge
- Key Switch

OPTIONAL EQUIPMENT

- Traction Drive Tire - Poly
- Straddle ID/OD of 34/42 or 42/50
- ClearView Polycarbonate Mast Guard
- 224 AH AGM Battery Pack w/110V charger
- Industrial Battery 255 AH with External Charger

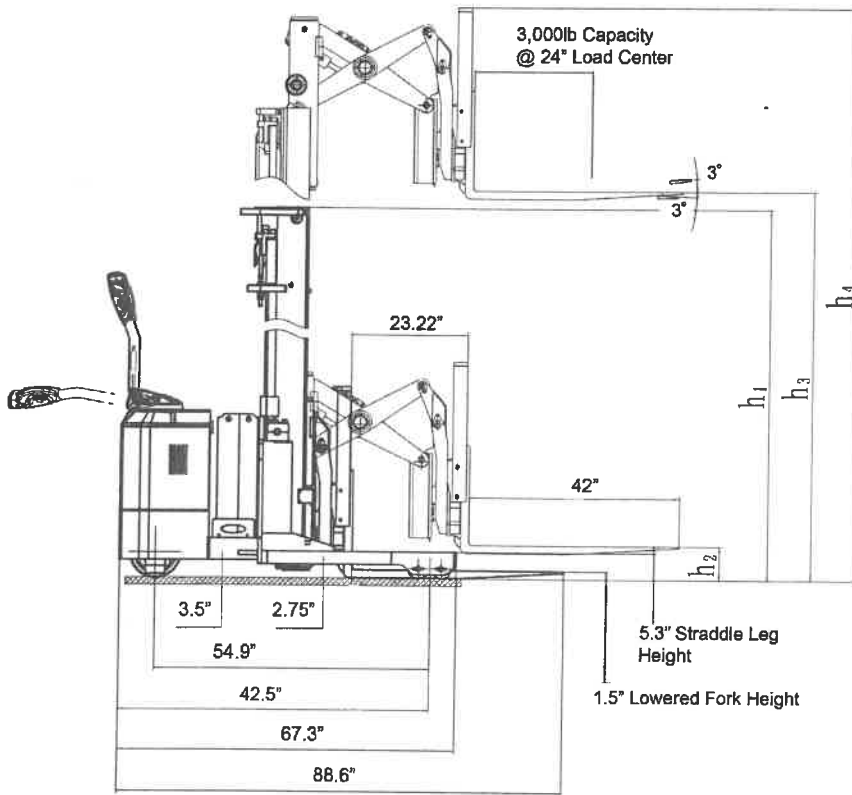

Overall length increased by up to 3\"/>

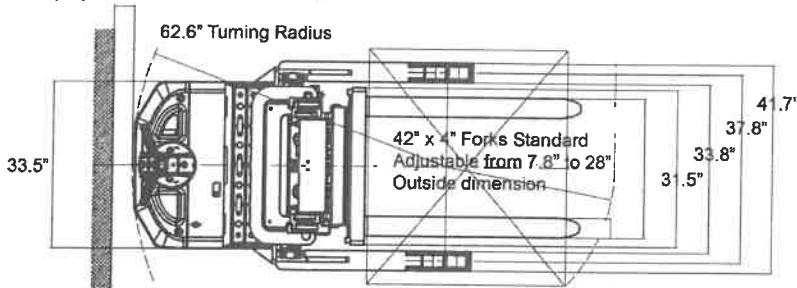

Aisle Guide

PDSR30 Right Angle Stack Dimensions with 42\"/>

Load Size	36\"/>		
36\"/>	79.5\"/>	79.5\"/>	79.5\"/>
40\"/>	81.0\"/>	81.0\"/>	81.0\"/>
48\"/>	85.3\"/>	85.3\"/>	85.3\"/>

For ease of use add 8\"/>

For units with 34\"/>

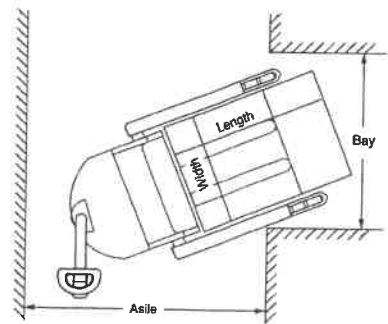

Aisle dimensions listed above assume the minimum bay width to be straddle OD plus 5\"/>

All measurements show in standard "inch" units

Truck Model 24\"/>	Straddle ID/OD	Mast	Lift Height (h3)	Collapsed Height (h1)	Free Lift (h2)	Extended Height (h4)	³ Weight (lbs)	
3000 lbs. Capacity								
PDSR30-106	34/42 or 42/50	Two Stage	106	73.5	6.5	144.25	3690	
PDSR30-126	34/42 or 42/50	Two Stage	126	83	6.5	166.75	3750	
PDSR30-157*	34/42 or 42/50	Three Stage	157	77.5	39.25	195.25	3980	
PDSR30-189**	42/50	Three Stage	189	95.0	39.25	227.00	4200	

*Derates 500lbs over 126"

**Derates 500lbs. over 126" and 1,500lbs. over 157"

³ Estimated shipping weight without battery